

Dell Systems Build and
Update Utility
Version 1.6

User's Guide



Notes



NOTE: A NOTE indicates important information that helps you make better use of your computer.

Information in this publication is subject to change without notice.

© 2011 Dell Inc. All rights reserved.

Reproduction of these materials in any manner whatsoever without the written permission of Dell Inc. is strictly forbidden.

Trademarks used in this text: Dell™, the DELL™ logo, PowerEdge™, and OpenManage™ are trademarks of Dell Inc. Microsoft®, Windows®, and Windows Server®, are either trademarks or registered trademarks of Microsoft Corporation in the United States and/or other countries. VMware® is a registered trademark of VMware, Inc. in the United States and/or other jurisdictions. SUSE® is a registered trademark of Novell, Inc. in the United States and other countries. Citrix® and XenServer® are either trademarks or registered trademarks of Citrix Systems, Inc. in the United States and/or other countries. Red Hat® and Red Hat Enterprise Linux® are registered trademarks of Red Hat, Inc. in the U.S. and other countries.

Other trademarks and trade names may be used in this publication to refer to either the entities claiming the marks and names or their products. Dell Inc. disclaims any proprietary interest in trademarks and trade names other than its own.

Contents

1	Overview	5
	About This Document	5
	Who Should Read This Document?	5
	How Will This Document Help Me?	5
	How Do I Use This Document?	5
	Dell SBUU Overview	7
	What's New in This Release	7
	Features of the Previous Release	7
	Function Overview	8
	Before You Begin Using SBUU	8
	Prerequisites and Requirements	8
	Generic Prerequisites and Requirements	8
	Server Operating System Installation Requirements	9
	Firmware Update Requirements	9
	Hardware Configuration Requirements	10
	Supported Operating Systems	10
	Supported Systems	10
	Other Documents You May Need	10
	How Do I Get Technical Assistance?	11

2	Launching SBUU	13
3	Using SBUU	17
	Using SBUU in Different Scenarios	19
	Updating Your System Firmware	19
	Configuring Your System Hardware	20
	Installing the Operating System	23
	Deploying Your Current "Bare-Metal" Dell System	25
	Deploying More Than One System With the Same Configuration	28
	Deploying More Than One System With Slightly Different Configurations	30
	Deploying Multiple Systems of Different Models	30
	Deploying Multiple Systems With the Same Configuration for Different Operating Systems	32
	Creating Bootable USB	33
4	Important Information and Frequently Asked Questions	37
	Firmware Update	37
	Important Information	37
	Frequently Asked Questions	37
	Hardware Configuration	38
	Server Operating System Installation	41
	Important Information	41
	Frequently Asked Questions	41

Overview

This chapter provides details on the information available in this document and where to find the required information. It also provides an overview of System Build and Update Utility (SBUU) and the prerequisites for using SBUU.

About This Document

It is strongly recommended that you read the current chapter before proceeding.

Who Should Read This Document?

This document is for system administrators who are responsible for deploying and updating Dell powered systems in their organizations.

How Will This Document Help Me?

This document introduces you to SBUU, and includes best practices on how to make the product effective in helping you streamline your deployment and update procedures for Dell systems.

- If you are a first-time user of this product, this document will help you set up your systems prior to, while, and after using SBUU.
- If you are an existing user of SBUU, this document will help you understand how to leverage the utility modules in an interlinked manner to create a customized deployment media.

How Do I Use This Document?

This document helps you set up your Dell systems to use SBUU effectively and efficiently and provides an overview of the various modules of SBUU and the possible scenarios in which you might use them. However, it does not cover all scenarios and possibilities. For specific information on Dell products whose functionalists are now provided by SBUU, see "Other Documents You May Need" on page 10.

Depending on the Dell systems you want to deploy, redeploy or update, it is recommended that you use the document as follows.

Table 1-1. Organization of Information in This Guide

Topics	For Dell systems
Information on this document, its intended audience, purpose, and organization	"About This Document" on page 5
Overview of SBUU and what functionalities it offers	"Dell SBUU Overview" on page 7
What you need before proceeding to use SBUU and where to get other information that you may need while using this utility	"Before You Begin Using SBUU" on page 8
Important information about launching the Systems Build and Update Utility and pointers to user scenarios	"Launching SBUU" on page 13
Possible scenarios in which you can use SBUU	"Using SBUU" on page 17
Important information and frequently asked questions (FAQs) about the Firmware Update module	"Firmware Update" on page 37
Important information and FAQs about the Hardware Configuration module	"Hardware Configuration" on page 38
Important information and FAQs about the Server Operating System Installation module	"Server Operating System Installation" on page 41

Dell SBUU Overview

This section provides an overview of the Systems Build and Update Utility (SBUU). This chapter helps you understand the functionalities that SBUU provides to update and deploy your Dell systems.

SBUU is an integrated tool for deployment and update of your Dell systems. It has modules such as **Server OS Installation**, **Firmware Update**, and **Hardware Configuration**. These modules enable you to update BIOS and firmware in the pre-operating system environment, apply these settings on the current system or on multiple systems, and install the operating system.

What's New in This Release

Support for:

- VMware ESX 4.0 U3
- VMware ESXi 4.0 U3
- VMware ESX 4.1 U1
- VMware ESXi 4.1 U1
- Citrix XenServer 5.6 FP1
- Microsoft Windows Server 2008 R2 x64 SP1
- Microsoft Windows Small Business Server 2011
- Universal Server Configurator (USC) Transition

Function Overview

Table 1-2 lists SBUU functions to deploy and update your Dell systems.

Table 1-2. Dell SBUU Functions

You Want To	Go To
Update your system firmware (Baseboard Management Controller [BMC], Dell Remote Access Controller [DRAC], Redundant Array of Independent Disks [RAID]) and BIOS in a pre-operating system environment.	"Updating Your System Firmware" on page 19
Configure your system hardware.	"Configuring Your System Hardware" on page 20

Table 1-2. Dell SBUU Functions (continued)

You Want To	Go To
Install an operating system on your system.	"Installing the Operating System" on page 23
Create customized bootable media to deploy multiple systems (different platforms) of your choice	"Using SBUU in Different Scenarios" on page 19

Before You Begin Using SBUU

This section lists the prerequisites for using SBUU and where to get other information that you may need while using this utility.

Prerequisites and Requirements

Dell system with:

- Minimum memory of 512 MB
- DVD drive

Generic Prerequisites and Requirements

- Two Network File System (NFS) or Samba multiple network shares. If you do not have network connectivity for the system you are deploying, ensure that you have multiple USB keys.
- If you are planning to deploy multiple systems using SBUU, it is recommended that you create a multi-system configuration file (.csv file) that contains information about all your systems on your network. Information includes the service tag, host name, IP addresses, subnet mask, operating system(s) ISO file name(s), product keys, DRAC IP address, and Domain Name System (DNS) IP addresses. Save this file on a common network share or a USB key.

SBUU does not validate the file but uses it during actual deployment.

When you want to apply your customized bootable media on a group of similar systems, SBUU prompts you to browse and locate the multi-system configuration file.

- A common network share or a USB key for the following actions:
 - Export your configuration
 - Save your customizable bootable image
- A common network share or a USB key to save your customized bootable image.
- A common network share to save logs for each system on your network share. These logs can be a useful reference if you want to troubleshoot any problem your systems might have encountered during deployment.

Server Operating System Installation Requirements

- Operating system media or a network share or a USB key on which to save the operating system ISO image.
- *Dell Systems Management Tools and Documentation* DVD (if you want to install Dell OpenManage System Administrator). This is not applicable for Dell PowerEdge SC systems.
- Basic knowledge of RAID.
- If you are using SBUU image downloaded from the support site and you want to install Microsoft Windows Server 2008, Windows OS Install Support Pack.

Firmware Update Requirements

Either of the following:

- DVD drive and *Dell Server Updates* DVD
- A network share with the Server Update Utility content and knowledge of setting up the NFS or Microsoft Windows share.

Hardware Configuration Requirements

- Basic knowledge of BIOS, RAID, BMC, and DRAC.

USC Transition

- 1 Insert the *Dell Systems Management Tools and Documentation* DVD in your media drive.
The boot menu is displayed.

2 Press < F3 > .

The **Advanced Options window/screen** is displayed.

3 Select **USCBOOT** to reboot the system to USC.

 **NOTE:** USC boot is supported only on 11g or later systems.

 **NOTE:** Ensure that iDRAC6/BMC and uEFI BIOS is preset and configured, and System Services and IMPI are enabled.

On 11g or later systems, you have an option to use USC or continue with SBUU.

Other Documents You May Need

In addition to this guide and SBUU online help, you might need to refer to the following documents to get details on specific SBUU modules and Dell OpenManage products. These documents are available at support.dell.com/manuals.

On the Manuals page, click **Software**→ **Systems Management**. Click the appropriate product link on the right-side to access the documents.

- The *Dell Remote Access Controller 5 Firmware User's Guide* provides comprehensive information about using the **RACADM** command line utility to configure a DRAC 5.
- The *Dell Chassis Management Controller User's Guide* provides comprehensive information about using the controller that manages all modules in the chassis containing your Dell system.
- The *Integrated Dell Remote Access Controller User's Guide* provides information about installation, configuration, and maintenance of the Integrated Dell Remote Access Controller (iDRAC) on management and managed systems.
- The *Command Line Reference Guide for iDRAC6 and CMC* provides information about the RACADM subcommands, supported interfaces, property database groups and object definitions for iDRAC6 and CMC.
- The *Dell Baseboard Management Controller Utilities User's Guide* provides information about configuring a managed system to use the BMC Management Utility to manage your system through its BMC.

- The *Dell Update Packages User's Guide* provides information about obtaining and using Dell Update Packages as part of your system update strategy.
- The *Dell OpenManage Deployment Toolkit User's Guide* provides information on how to run Linux DUP in the Dell-provided or your customized Embedded Linux (ELI) environment considering the dependencies.
- The *Dell OpenManage Deployment Toolkit Command Line Interface Reference Guide* provides general, best practice procedures on how to run the Deployment Toolkit (DTK), which is a set of command line tools for configuring and deploying Dell PowerEdge systems.
- The *Server Update Utility User's Guide* provides information on how to identify and apply updates to your system.
- The *Dell Systems Software Support Matrix* provides information about the various Dell systems, the operating systems supported by these systems, and the Dell OpenManage components that can be installed on these systems.
- The *Glossary* provides information about the terms used in this document.

How Do I Get Technical Assistance?

If at any time you do not understand a procedure described in this guide or if your product does not perform as expected, help tools are available to assist you. For more information about these help tools, see "Getting Help" in your system's *Hardware Owner's Manual*.

Additionally, Dell Enterprise Training and Certification is available. See www.dell.com/training for more information. This service may not be offered in all locations.

Launching SBUU

To launch SBUU locally:

- 1 Insert the *Dell Systems Management Tools and Documentation* DVD in your system drive.
- 2 Reboot your system.
The boot menu screen appears.

To launch SBUU on a remote system:

- 1 In the Dell Remote Access Controller (DRAC) 4, DRAC 5, or iDRAC, click the **Media** tab.

The **Virtual Media** screen appears.

 **NOTE:** If the Virtual Media Active X Control is not installed on the system, you are prompted to install it before you proceed.

- 2 Ensure that the attribute for **Attach/Detach Status** is **Attached**.
- 3 Specify the location of the **ISO Image File**.

To access the location of SBUU bootable media or the ISO image of the *Dell Systems Management Tools and Documentation* DVD, select your system drive location or browse to identify the **ISO Image File**, as appropriate.

- 4 Click **Connect**.

The **Virtual Media Status** screen appears indicating that the *Dell Systems Management Tools and Documentation* media is now connected to your host system.

- 5 Click **Power Management**.

- 6 To boot the host system with the Systems Build and Update media, select **Power Cycle System** under **Power Control Operations**, and click **Apply**.
- 7 Click **Console**.
The **Console Redirection** screen appears.
- 8 Click **Connect**.
You can now access the boot menu screen on your host system from your client system and proceed to use SBUU remotely.

Figure 2-1. Boot Menu Screen

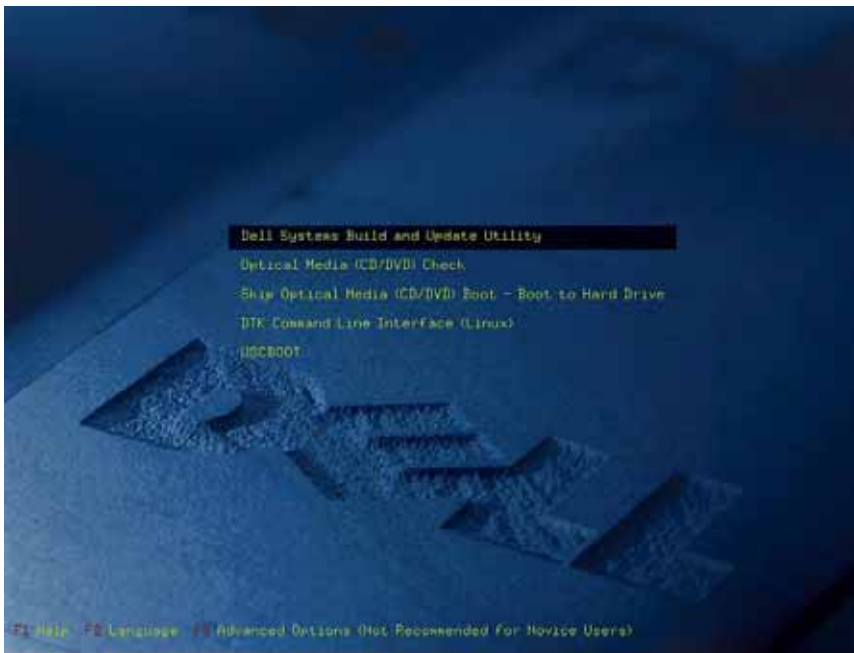

Table 2-1 lists the options and their descriptions available on this screen.

Table 2-1. Boot Menu Options

Boot Menu Option	Action
Dell SBUU	Takes you to the Dell Systems Build and Update Utility Home screen.
Optical Media (CD/DVD) Check	Checks if the <i>Dell Systems Management Tools and Documentation</i> DVD you inserted has any errors.
Skip Optical Media (CD/DVD) Boot - Boot to Hard Drive	Enables you to boot from your system hard drive.
DTK Command Line Interface (Linux)	Takes you to the Deployment Tool Kit (DTK) Command Line Interface (only on systems running Linux). NOTE: This option is not available on Dell PowerEdge SC systems.
F1 Help	Takes you to the navigation help.
F2 Language	Enables you to choose the language.
F3 Advanced Options	Activates the DTK Command Line Interface (Linux) option. NOTE: This option is not available on Dell PowerEdge SC systems.

You may want to use SBUU in any of the following possible scenarios:

- "Updating Your System Firmware" on page 19
- "Configuring Your System Hardware" on page 20
- "Installing the Operating System" on page 23
- "Deploying Your Current "Bare-Metal" Dell System" on page 25
- "Deploying More Than One System With the Same Configuration" on page 28
- "Deploying More Than One System With Slightly Different Configurations" on page 30
- "Deploying Multiple Systems of Different Models" on page 30
- "Deploying Multiple Systems With the Same Configuration for Different Operating Systems" on page 32
- "Reusing Configuration Files" on page 35

Using SBUU

This chapter describes the flexibility that SBUU offers to deploy and update your systems and also the various scenarios in which you can use SBUU.

SBUU offers the following options:

- **Choice of configuration:** Depending on your deployment and update requirement, you can configure all three of the modules (**Firmware Update, Hardware Configuration, and Server Operating System Installation**), any one of the modules, or a combination of the modules.
- **Choice of when to apply the configuration:** You can either apply the configuration of your choice immediately or save it by using the **Apply/Export Configuration** feature.
- **Choice of configuring systems:** The **Apply/Export Configuration** feature in SBUU allows you to deploy and update your current system and/or multiple systems or multiple systems of different models.
 - You can perform the following deployment/update operations on your current system:
 - apply firmware updates
 - configure hardware (BIOS, DRAC, RAID, and so on)
 - install an operating system
 - launch post-operating system install scripts
 - You can perform the following deployment or update operations for multiple systems:
 - export the configuration scripts (for all three modules or a combination of your choice) for future use.
 - generate a bootable image that contains, among others, the update packages for specific generation(s) of system(s), applicable hardware configuration scripts (BIOS, DRAC, RAID, and so on), operating system installation details and link to the source CD/DVDs on the network, and launch points to install the operating system.

- **Choice of creating bootable media:** You can create bootable media for a set of systems you select and then use the same media to boot each system in the set. If you select the USB drive as the destination for the image, SBUU gives you the option to make the USB device bootable and directly boot the system with the device.
- **Unattended update and deployment:** When you boot your system using the bootable media (CD/DVD/USB drive), the scripts on the bootable media you created apply the firmware updates, apply the hardware configuration, and finally install the operating system, as applicable. All through this update and deployment process, you are not prompted for any information, making this an unattended update and deployment of your system.



NOTE: **Content Manager** is no longer available on the *Dell Systems Management Tools and Documentation* DVD. To access **Content Manager**, use version 5.5 of the *Dell Systems Management Tools and Documentation* DVD. You can also use Repository Manager that can be downloaded from support.dell.com.

Using SBUU in Different Scenarios

This section describes some of the possible scenarios in which you can use SBUU. These scenarios are meant to give you an idea on how to effectively use SBUU. They are not necessarily the only ways to use this tool nor are they the only scenarios in which you can use this tool.

It is recommended that at any point during your update and deployment process, you see the online help for details about a particular screen.

Updating Your System Firmware

If you have purchased a newly released Dell PowerEdge system, it is likely to have the latest firmware. However, if more than a quarter has passed since the release of your system, you may have to update the firmware.

- 1 On the **Dell Systems Build and Update Utility Home** screen, click **Configure** against **Firmware Update** or click **Firmware Update** on the left pane.

The **Repository Selection** screen of the **Firmware Update** module appears.

- 2 Specify the location where your update files repository resides. For details, see "Firmware Update" on page 37. For more details on repository selection, see the online help.

If you want to compare your system component status with a different version of the Server Update Utility, provide the location of the Server Update Utility on the **Repository Selection** screen.

- 3 Click **Continue**.

The **Firmware Update** inventories your system and generates a comparison report on the **Comparison Report** screen.

This screen displays a comparison of the currently installed version of each component on the existing system with the repository component version for the same system. It also indicates the components that you need to upgrade and those that you can downgrade.



NOTE: The **OM_FRMW_LX_R241387.BIN** component provides an update for Dell Embedded OMSA on VMware embedded ESXi 4.x hypervisor. Select this only if the server has ESXi 4.x. After installing this component, enable CIM

OEM providers before accessing it. For more information on how to enable CIM OEM providers, see the *Dell OpenManage Server Administrator Version 6.2 Installation Guide* at support.dell.com/manuals.



NOTE: You can selectively upgrade components depending on your requirement. However, you cannot perform selective downgrades.

- 4 Select any components that you might want to upgrade and click **Systems Build and Update Utility Home**.



NOTE: SBUU saves the information about the repository and the selections you made on the **Comparison Report** screen. These updates are applied during the actual deployment.

- 5 To update your current system, click **Apply/Export Configuration** on the **Systems Build and Update Utility Home** screen.

The **Configure Apply /Export Options** screen appears.

- 6 Select the **Apply Configuration to Current System** option and click **Apply/Export**.

The progress bar appears after which your system reboots with the firmware updates configured.



NOTE: For more information on the specific **Firmware Update** screens and what you can do on each screen, see the *Systems Build and Update Utility* online help.

Configuring Your System Hardware

On Your Current System

- 1 On the **Systems Build and Update Utility Home** screen, click **Configure** against **Hardware Configuration** or click **Hardware Configuration** on the left pane.

The **Configuration Status Summary** screen appears.

- 2 To configure the components (RAID, DRAC, BIOS, and so on), click the individual component buttons.

Component screens appear, on which you can configure various components.



NOTE: If you configure RAID manually and use SBUU to install an operating system on a master system, you need to manually configure RAID on the target system as well.

- 3 After you configure fields on each component screen and before you navigate away from the screen, click **Save Settings** and then click **Go Back to Configuration Summary**.
- 4 On the **Configuration Status Summary** screen, click **Save Settings and Go Back to Home Page**.
- 5 On the **Systems Build and Update Utility Home** screen, click **Apply/Export Configuration**.

The **Configure Apply/Export Options** screen appears with the **Apply Configuration to Current System** option selected, by default.

You can export the hardware configuration for later use by selecting **Export Configuration**.

- 6 Click **Apply/Export**.

A progress bar appears indicating that the configuration changes you saved in step 3 are being applied to your system. After the changes are applied, your system reboots automatically and is ready for use with the updated configuration.

For Multiple Systems

- 1 On the **Systems Build and Update Utility Home** screen, click **Change against System(s) Selection** on the left pane.

The **Select System(s)** screen appears.

- 2 Select the system(s) on which you want to deploy the hardware configuration you specify.



NOTE: To generate a bootable ISO image to deploy a hardware configuration to multiple systems, you must select all the required systems on the **Select System(s)** screen even if they are of the same model as your current system on which you are running SBUU.

- 3 Click **Save Settings**.

The **Systems Build and Update Utility Home** screen reappears listing the selected systems under **System(s) Selection**.

- 4 Click **Configure** against **Hardware Configuration** or **Hardware Configuration** on the left pane.

The **Configuration Status Summary** screen appears.

- 5 To configure the components (RAID, DRAC, BIOS, and so on), click the individual component buttons.

Component screens appear on which you can configure various components.

- 6 After you configure fields on each component screen, click **Save Settings** and then click **Go Back to Configuration Summary**.

- 7 On the **Configuration Status Summary** screen, click **Save Settings and Go Back to Home Page**.

- 8 On the **Systems Build and Update Utility Home** screen, click **Apply/Export Configuration**.

The **Configure Apply/Export Options** screen appears with the **Create Auto-Deployment Bootable Image** option selected, by default.

You can export the hardware configuration for later use by selecting **Export Configuration**.

- 9 Click **Destination** to provide the location where you want to save the bootable ISO image.

The **ISO Save Location** screen appears.

- 10 Specify the location and click **Continue**.

- 11 Click **Apply/Export**.

The ISO image is generated and saved in the location you specified in the preceding step. If the destination you specified is not a bootable USB key, burn the ISO image using any CD/DVD burning software application on to a CD or a DVD.

- 12 Boot the selected systems with the bootable media you created.

The deployment starts automatically and you are not prompted for any inputs. The system reboots as and when required until the selected systems are ready with the updated configuration.

Installing the Operating System

- 1 On the **Systems Build and Update Utility Home** screen, click **Configure** against **Server OS Installation** or click **Server OS Installation** on the left pane.

The **Set the Date and Time** screen appears.

 **NOTE:** If you want to install ESXi Flash or HDD, insert an SD card or USB key.

- 2 Make the required changes and click **Continue**.

The **Select an Operating System to Install** screen appears.

- 3 Select the appropriate operating system, choose whether you want to create a utility partition, and click **Continue**.

 **NOTE:** The utility partition does not have DOS-based RAID tools.

For this procedure, let us assume that you select the Microsoft Windows Server 2003 R2 operating system and choose to create a utility partition.

The **Select RAID Configuration** screen appears.

- 4 Indicate whether you want to apply the RAID configuration that you specified while configuring your system hardware in the **Hardware Configuration** module or retain the existing RAID configuration on your system and click **Continue**.

The **Configure the Disk Partition for Microsoft Windows Server 2003 R2** screen appears.

- 5 Select the file system for boot partition, enter the size of the virtual disk available, and click **Continue**.

The **Network Adapter(s) Configuration** screen appears.

- 6 Enter the appropriate information about the network adapters on your system. Click **Continue**.

The **Enter Configuration Information for Microsoft Windows Server 2003 R2** screen appears.

- 7 Fill in the appropriate fields and click **Continue**.

The **Operating System Installation Summary** screen appears.

- 8 Click **Back** to change settings if required.

You can also save your configuration and export it for later use by clicking **Go Back to Home Page**. In this case, continue the current procedure from step 9.

To apply the configuration on your system immediately, click **Apply Now**. In this case, continue the current procedure from step 11.

 **NOTE:** The **Apply Now** option is enabled only if you have not selected any system on the **Select System (s)** screen.

- 9 In the **Systems Build and Update Utility Home** screen that appears, click **Apply/Export Configuration**.

The **Configure Apply/Export Options** screen appears with the **Apply Configuration to Current System** option selected, by default. You can export the operating system installation configuration for later use by selecting **Export Configuration**.

- 10 Click **Apply/Export**.

The **Script Generation Progress** screen appears indicating that the configuration is being saved.

- 11 If you selected the option to install the Dell OpenManage Server Administrator on the **Enter Configuration Information for Microsoft Windows Server 2003 R2** screen, specify the location of either the Server Administrator CD or the Server Administrator .exe file on your system.

- 12 Insert the operating system CD/DVD when prompted.

SBUU copies the operating system files to your system and launches the operating system installer. Your system may reboot multiple times.

 **NOTE:** If you are using the SBUU iso image downloaded from support.dell.com and installing Microsoft Windows Server 2008 32-bit or 64-bit, and Windows Small Business Server 2011, download **Windows OS Install Support Pack** package from the support site. Create your own optical media from the **Windows OS Install Support Pack** package and make it available to SBUU when prompted.

The operating system is installed and is ready to install Server Administrator. The files to install Server Administrator are saved on the system and the Install Server Administrator icon is saved on the desktop.

Deploying Your Current "Bare-Metal" Dell System

In this scenario, you can see how to update and deploy your current system.

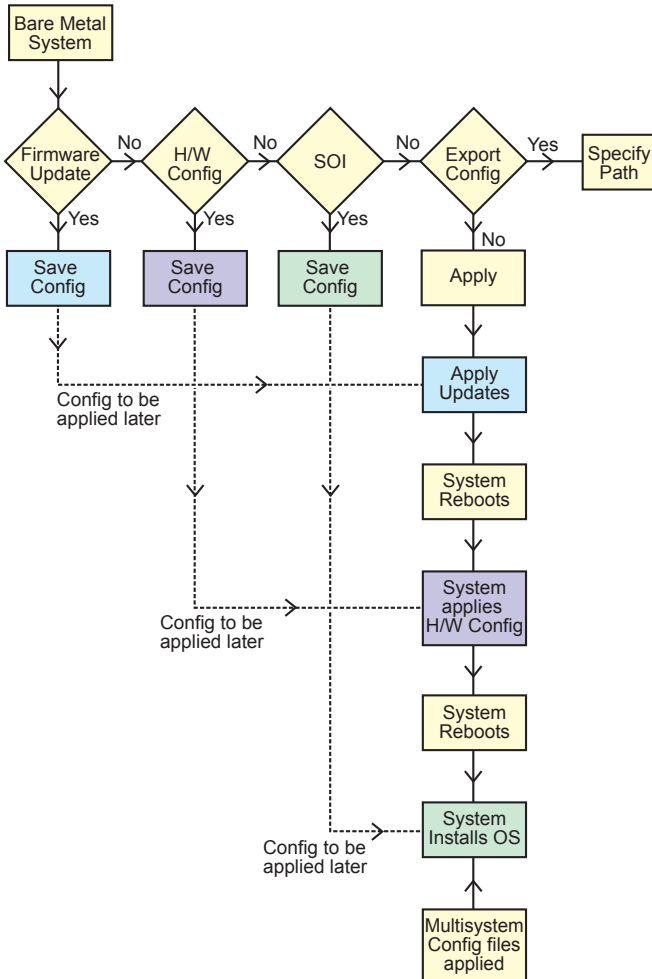

- 1 Update your system firmware, if required.

For details on the **Firmware Update**, see "Firmware Update" on page 37. For details on how to use the Firmware Update module, see step 1 through step 4 under "Updating Your System Firmware" on page 19.

- 2 Configure your system hardware and make sure you click **Save Settings** before you navigate away from a component screen.

For details on the Hardware Configuration module, see "Hardware Configuration" on page 38. For details on how to use the Hardware Configuration module, see "Configuring Your System Hardware" on page 20.



NOTE: Ensure that you configure RAID to proceed beyond the **Configure RAID** screen in the **Configure Server Operating System Installation** module.

- 3 Click **Configure** against **Server OS Installation** on the **Systems Build and Update Utility Home** or click **Server OS Installation** on the left pane to proceed with configuring your system operating system installation.

For details on the Server OS Installation, see "Important Information and Frequently Asked Questions" on page 37. For details on how to use the Server OS Installation module, see "Installing the Operating System" on page 23.

- 4 When you have completed configuring the three modules, you can view, edit, or reset the configuration for the modules by clicking the **View**, **Edit**, or **Reset** options, respectively.
- 5 On the **Systems Build and Update Utility Home**, click **Apply/Export Configuration**.

The **Configure Apply/Export Options** screen appears.

- 6 Provide your inputs as required and click **Continue**.



NOTE: You can choose to configure the multi-system configuration file so that system settings are taken from this file.



NOTE: You can check the **Exit on Failure** option so that SBUU exits when a failure occurs. If this option is not selected, in case of any failure during actual deployment, SBUU proceeds to the next module operation. However, this may cause your system to become unstable. Clear the **Exit on Failure** option only if you are sure that the failure is known and will not adversely affect your system.



NOTE: For more information on the specific fields on the **Select Options** screen, see the Dell Systems Build and Update Utility online help.

The progress screen appears, after which the unattended update or deployment begins. If you have provided updates to your system firmware, the firmware update begins, using the configuration you saved. If any of the firmware updates requires a system reboot, your system reboots automatically. Then, SBUU continues with hardware configuration and operating system installation, as per your configuration. This completes your current system update and deployment. Your system is ready with all the required settings, configurations, and updates and the operating system installed.

Deploying More Than One System With the Same Configuration

In this scenario, you can deploy more than one supported system with the same configuration (that is, having the same cards, controllers, hard drive, memory, and so on), for example, 50 Dell PowerEdge R710 systems.

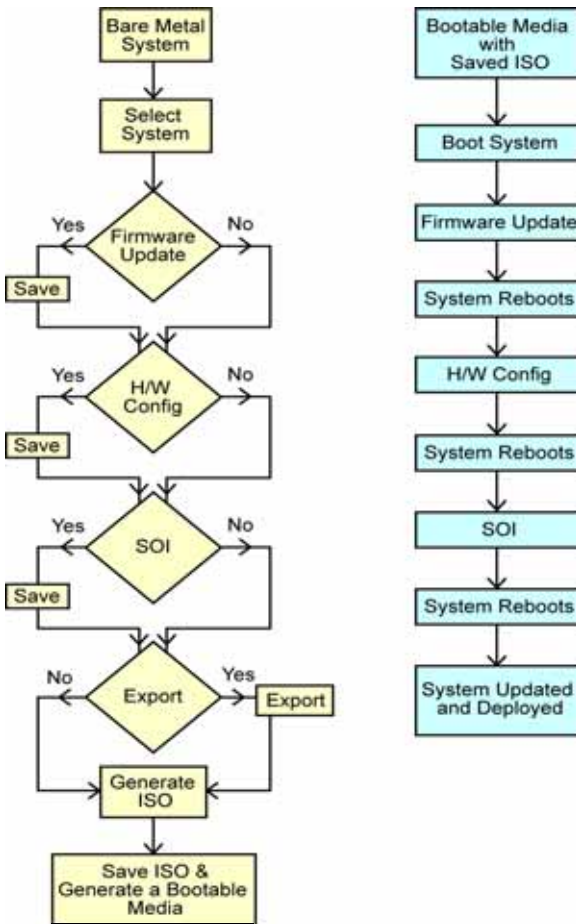

- 1 On the **Systems Build and Update Utility Home** screen, click **Change** against **System(s) Selection** on the left pane.

The **Select System(s)** screen appears.



NOTE: Ensure that you click **Select Systems** so that the option to save the ISO image (**Create Auto-deployment Bootable Image**) is enabled on the **Select Options** screen.

- 2 Select **PowerEdge R710** (for this example) from the Supported Systems list and click the right arrow.
- 3 Click **Save Settings** and return to the **Systems Build and Update Utility Home** screen.
- 4 To configure the Systems Build and Update Utility modules, follow step 1 through step 4 in "Deploying Your Current "Bare-Metal" Dell System" on page 25.
- 5 On the **Systems Build and Update Utility Home** screen, click **Apply/Export Configuration**.

The **Configure Apply/Export Options** screen appears.

- 6 Select the **Create Auto-deployment Bootable Image** option and click **Destination** to specify the location where you want to save the ISO image. You can also export the configuration you saved in the preceding steps to a location of your choice.
- 7 On the **ISO Save Location** screen, specify the location where you want to save the ISO image and click **Continue**.

If you choose USB as the location, you can also make the USB key bootable. See the online help for details.

The **Configure Apply/Export Options** screen appears.

- 8 Click **Apply/Export**.

The ISO image is created.

You can create a bootable media (CD/DVD) or use the bootable USB key to boot the systems that you want to update or deploy.

Deploying More Than One System With Slightly Different Configurations

In this scenario, you can see how to deploy more than one supported system with slightly different configurations. For example, you can configure 50 PowerEdge R710 systems but the systems may have different cards, controllers, hard drives, memory, and so on. However, for the update and deployment to work as in the preceding scenario, the following conditions must be met:

- the same type of controller that is configured must be present, whether the controller is onboard or in the slot. For controllers in slot, the controller must be on the same slot as configured.
- the configured RAID level must be supported by the existing controller. Serial Attached SCSI (SAS) 5 and SAS 6 controllers require a minimum of 2 disks.
- the configured RAID policy must be supported by the current controller.
- the number of disks must be the same or more.
- the disk sizes are the same or more.
- the available disks must be of the same type. For example, a mix of SAS, small computer system interface (SCSI), and Solid State Disk (SSD) will not be supported.

Once the above criteria are satisfied, you can follow step 1 through step 8 in "Deploying More Than One System With the Same Configuration" on page 28 to update and deploy more than one system with slightly different configurations.

Deploying Multiple Systems of Different Models

In this scenario, you can deploy multiple systems of different models; for example, you can deploy 25 PowerEdge R710 systems, 50 PowerEdge R610 systems, and 25 PowerEdge T610 systems.

To deploy multiple systems of different models, do the following:

- Ensure that you select multiple systems that you want to deploy on the Select System(s) screen.
- The Firmware Update module displays all the update packages for the systems you selected. Depending on the system model, you must select the components that need to be updated.

- The Hardware Configuration module displays all the configuration options under different tabs. Ensure that you select all relevant options for all the systems you selected.
- The list of operating systems displayed in the Server Operating System Installation (SOI) module is a subset of supported operating systems that can be installed across the selected systems. This implies that if you select systems that have no supported operating systems in common, the SOI module will not display any operating system and you will not be able to proceed with the deployment process.

To deploy multiple systems of different models, follow step 1 through step 8 in "Deploying More Than One System With the Same Configuration" on page 28.

Deploying Multiple Systems With the Same Configuration for Different Operating Systems

In this scenario, you can update and deploy multiple systems with the same configuration for different operating systems. For example, you have 100 PowerEdge R710 systems and you want to deploy 25 systems with the Microsoft Windows Server 2003 operating system, 50 systems with the Red Hat Enterprise Linux 5 Update 3 operating system, and 25 systems with the Windows Server 2008 operating system.

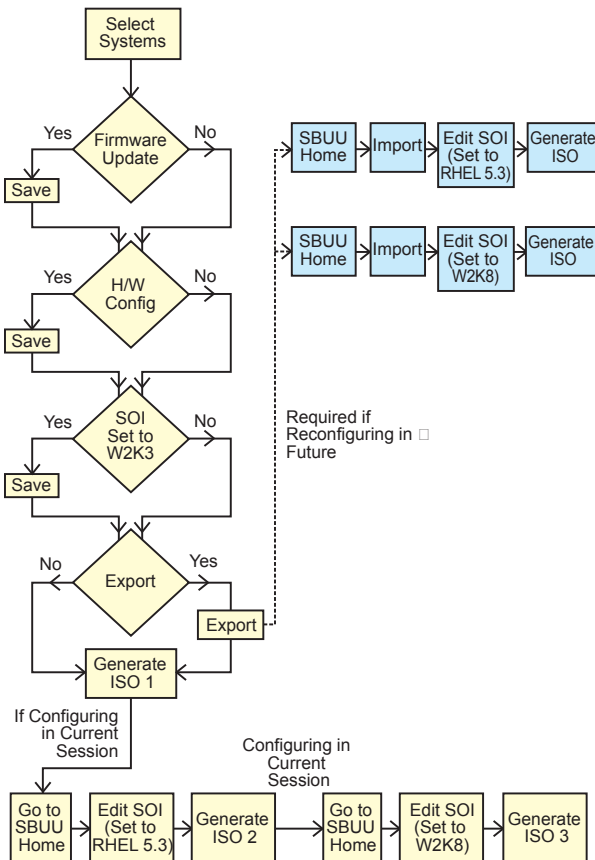

- 1 Follow step 1 through step 8 in "Deploying More Than One System With Slightly Different Configurations" on page 30 to create a bootable image to deploy an operating system, for example, Windows Server 2003 operating system.

On the **Systems Build and Update Utility Home** screen, click **SOI**.

On the **Select an Operating System to Install** screen, select Windows Server 2003.

If you also export the configuration, you can import this configuration later (in another session) by clicking **Import Saved Configuration** on the **Systems Build and Update Utility Home** screen.

- 2 On the **Systems Build and Update Utility Home** screen, click **SOI** and select another operating system, for example, Red Hat Enterprise Linux 5.3, export the configuration for this operating system, and generate an ISO image.
- 3 Similarly, configure and generate an ISO image for a third operating system, for example, Windows Server 2008.

You now have three ISO images for the three operating systems you want to install on multiple systems.

- 4 Create three different bootable media for the three ISO images, respectively.
- 5 Boot the corresponding number of systems with the corresponding bootable media to install the required operating systems.

Creating Bootable USB

You can create a bootable USB key from the Dell OpenManage DVD image on Red Hat Enterprise Linux and SUSE Linux Enterprise operating systems.

To create a bootable USB:

- 1 Plug in the USB key in the system.

 **NOTE:** Ensure that no other USB media is mounted on the system.

 **NOTE:** Ensure that the size of the USB key is more than that of DVD image.

- 2 Insert the Dell OpenManage DVD in the system.
- 3 To see all the connected USB media devices, type the following command:

```
/media/cdrom/server_assistant/driver_tool/src/make_bootable_usb.sh --scan
```

- 4 To create the bootable USB media from the Dell OpenManage DVD, type the following command:

```
/media/cdrom/server_assistant/driver_tool/src/make_bootable_usb.sh <path-to-mounted-dvd> <path-to-usb-device>
```

Example:

```
/media/cdrom/server_assistant/driver_tool/src/make_bootable_usb.sh /media/cdrom /dev/sdb
```

- 5 Remove the USB key and use this key to boot the target system.



NOTE: If the Linux automount feature is active on the USB device, unmount the USB before removing it.

Reusing Configuration Files

In this scenario, you can import and reuse a configuration file that you created and exported in an earlier session. You can use this configuration file and create multiple ISO images with slightly different configuration. This configuration can be for the current system or for multiple systems. However, you need to create separate ISO images for every variation of the multiple systems deployment. For the current system, you can directly apply the configuration you imported, with slight modifications, if required.

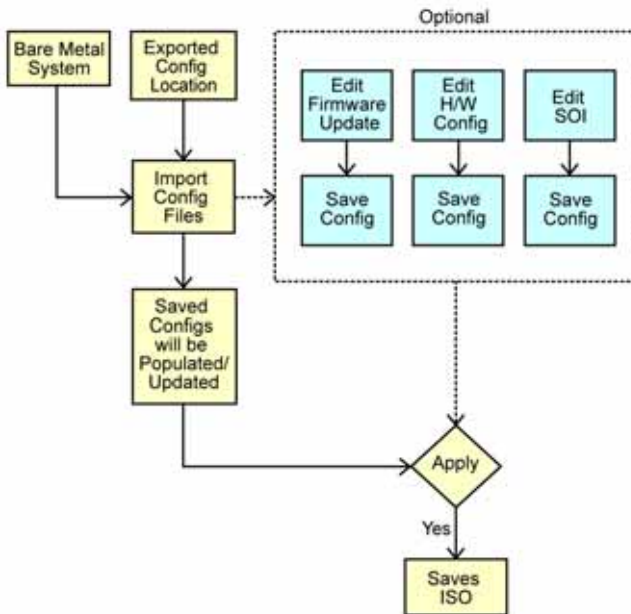

NOTE: When you import the configuration file, all the GUI fields are populated. You can edit the Firmware Update Configuration, Hardware Configuration, and Configure SOI modules, as required. However, ensure that you do not make any changes on the System(s) Selection screen; if you do so, all existing configuration for the three modules will be reset.

- 1 On the **Systems Build and Update Utility Home** screen, click **Import Saved Configuration**.

The **Import Configuration** screen appears.

- 2 Specify the location from where you want to import the configuration file and click **Continue**.

The progress screen appears, followed by the **Imported Configuration File Details** screen.

- 3 Click **Systems Build and Update Utility Home**.

- 4 Edit the existing configuration for the **Firmware Update**, **Hardware Configuration**, and **SOI** modules, if required.

- 5 Create the ISO image for this configuration by following step 4 through step 8 in "Deploying More Than One System With the Same Configuration" on page 28.

Important Information and Frequently Asked Questions

This chapter contains important information about the different modules in SBUU, including answers to some frequently asked questions.

Firmware Update

Important Information

The **Firmware Update** module in SBUU enables you to update the BIOS and firmware versions of your Dell systems in a pre-operating system environment. This module:

- inventories your system (BIOS, firmware, and drivers)
- enables you to select your own repository
- generates a comparison report (comparison of the currently installed version of each component on the existing system with the repository component version for the same system)
- enables you to upgrade the system components

Frequently Asked Questions

Q: What is the repository?

A: The repository contains the updated BIOS, firmware, and driver components for Dell systems.

The *Dell Server Updates* DVD includes the repository.

Q: What should I do if I face any prerequisite failure during the update process?

A: If you face any prerequisite failure during the update process, see the *Server Update Utility User's Guide* on how to rectify this.

Q: I want to use my custom repository for firmware updates using SBUU.

A: If you want to use your custom repository for firmware updates using SBUU, you need a Linux repository. Also, you must ensure that the repository contains updates for the system on which you want to run firmware updates.

Q: What should I do if I want to downgrade the firmware?

A: If you want to downgrade the firmware, you cannot do it using the **Firmware Update** module. Use the *Dell Server Updates DVD* to downgrade the firmware on your system.

Q: What should I do if some of the updates fail?

A: If some of the updates fail, reboot your system and try using the latest repository to update the firmware. Also, see the *Server Update Utility User's Guide* for more information.

Q: I want to use a USB key as my source repository.

A: If you are using a USB key as your source repository, insert the USB key when you are prompted.



NOTE: It is recommended that you do not boot your system to SBUU with the USB key inserted in your system. This is because SBUU may not detect a USB key that is inserted before you boot the system.

Hardware Configuration

Important Information

The **Hardware Configuration** module in SBUU enables you to configure your system's Baseboard Management Controller (BMC), Dell Remote Access Controller (DRAC), Redundant Array of Independent Disks (RAID), and BIOS.

Once you save the configuration settings for your system's BMC, DRAC, RAID, and BIOS, you can use the tool to generate the **.ini** file, and apply these configuration settings across multiple systems.

Frequently Asked Questions

Q: How do I access the command line interface?

A: To access the command line interface, from the boot menu, select **DTK Command Line Interface (Linux)**.

Q: How do I know which components to configure?

A: Select the system that you want to configure. In the left pane, SBUU displays the components that you can configure. Click the component. The right pane displays the options that you can configure for the selected component.

Q: Where do I get more information on RAID controllers?

A: For details on read, write, and cache policies and supported stripe sizes, see the *Dell OpenManage Deployment Toolkit Command Line Interface Reference Guide*.

Q: How do I know which BIOS setup options are available on my system?

A: To see which BIOS setup options are available on your system, go to the boot menu screen and select **DTK Command Line Interface (Linux)**. Use the SYSCFG tool to see the list of options available on your system.

Q: When setting the boot sequence for devices, what happens if I choose a device that is not on my system?

A: The configuration utility selects the boot devices in the sequence that you specify for boot order. However, if you choose a device that is not present on your system, the utility ignores the device, selects the remaining boot devices, and lists them based on the specified order.

Q: What happens if I create a virtual disk by specifying the size?

A: If you create a virtual disk by specifying the size (instead of using the **Maximum possible size** option), subsequent virtual disks that you create is bound to the controller and the array disk that you selected. This condition is valid until you exhaust all the available space on that array disk.

Q: What happens if I want to delete a virtual disk that is one of the virtual disks that was created using a particular array disk?

A: When you select a virtual disk to delete, and that virtual disk is just one of the virtual disks that was created using a particular array disk, all the virtual disks created on that array disk are selected for deletion.

Q: What should I do if I am not able to configure RAID using SBUU?

A: Ensure that the **Fast Initialization** parameter of the RAID controller is set to ON and try again. This setting is the factory default for all RAID controllers.

Q: Using SBUU, can I configure RAID on a system with a SATA 2s controller connected to a hard drive?

A: SBUU does not support RAID configuration on any system with a SATA 2s controller connected to a hard drive. To configure RAID on such a system, use the < Ctrl> < A> option or set the hard drive configuration to **Native** mode through BIOS.

Q: I have multiple SCSI and RAID controllers on my system. How can I set the order in which SBUU looks for controllers?

A: SBUU uses the controller listed first in the BIOS boot order list. If you want to use another controller for the operating system, go to the BIOS setup (by pressing F2 as the system starts) and set the controller as the first boot device.

Q: What should I do if I find that one or more virtual disks are in a failed or degraded state?

A: If any virtual disk is in a failed or degraded state, do not start the server setup program. Use the RAID controller's firmware utility (by using < Ctrl> < A> , < Ctrl> < M> , or < Ctrl> < C> while booting) to reset the RAID controller's state.

Q: How can I configure RAID for disks that appear in **Legacy** mode?

A: On CERC ATA or CERC SATA RAID controller cards, disks that appear in **Legacy** mode is not available for RAID configuration in SBUU. If you want to use **Legacy** mode disks as part of a RAID container, use the RAID controller firmware utility to initialize the disks. However, if all disks are in **Legacy** mode, SBUU may fail to configure RAID on the controller.

Q: Why does the Novell SUSE Linux Enterprise Server (SLES) version 10 operating system installation sometimes fail on systems equipped with multiple RAID and SCSI controllers?

A: When two or more RAID or SCSI controllers are present, install Novell SLES I0 with only one configured RAID or SCSI controller. Configure the other controllers after you install the Novell 10 operating system.

Server Operating System Installation

Important Information

The **Server Operating System Installation** (SOI) module in SBUU enables you to install Dell-supported operating systems on your Dell systems. SOI also maps the operating system you want to install to your system and installs the requisite drivers. It also has a simple interface to configure Dell-supported storage controllers.

You can use SOI to:

- deploy an operating system on your "bare-metal" Dell system (that is, when your system does not have an operating system installed on it).
- "repurpose" your system (that is, your system already has an operating system installed on it, and you want to install a different operating system).
- extract drivers and save them on a directory on your system.

Frequently Asked Questions

Q: What happens if I install a new operating system on my system that already has an operating system?

A: If you already have an operating system on your system (that is, if you are "repurposing" your system), and you use the SOI to install a different operating system, the existing operating system is removed and data is deleted from your system.

Q: Can I install Microsoft Windows Server 2008 and VMware ESX Server operating systems?

A: Yes, you can. However, for operating systems such as Windows Server 2008 and VMware ESX Server, the native Graphical User Installation tool provided by the operating system installation media is used.

Q: What happens if I disconnect the network connection while I am copying the operating system image from a Server Message Block (SMB) share?

A: If you disconnect the network connection while the operating system image is copying, an error message appears indicating that the network is being disconnected. A **Reboot** button is also enabled. However, the operating system installation process does not resume after you reconnect the network cable. You need to reboot your system.

Q: What happens if I use the SOI to configure Redundant Array of Independent Disks (RAID) controllers on my system that has virtual disks configured on the controller?

A: If you have virtual disks configured on your controller and you use the **SOI** to configure RAID controllers on your system, the existing virtual disks are deleted.

Q: Where can I get information about support for operating systems and RAID controllers?

A: Some operating systems are not supported with some RAID controllers. See the **readme.txt** file in the **root** folder for details.

Q: Where can I get information on support for storage controllers and operating systems?

A: Depending on the storage controllers on your system, some operating systems may not be supported. See **readme.txt** in the **root** folder of the *Dell Systems Management Tools and Documentation DVD* or the online help for details.